

DN15 – DN150 resp. ½" – 6"

are ideally suited as reliable flow indicators for virtually all existing process media in either liquid or even gaseous state.

Modular Design

Sight Glasses SSP Series are available as DIN- or ANSI-types, with sight glass window plates made of Borosilicate acc. to DIN 7080 as per standard.

The sturdy design bodies are made of cast steel 1.0619 (WCB), coating RAL 5005 signal-blue or stainless steel casting 1.4408 (CF-8M), with resistant linings such as PFA or PFA-AS (anti-static).

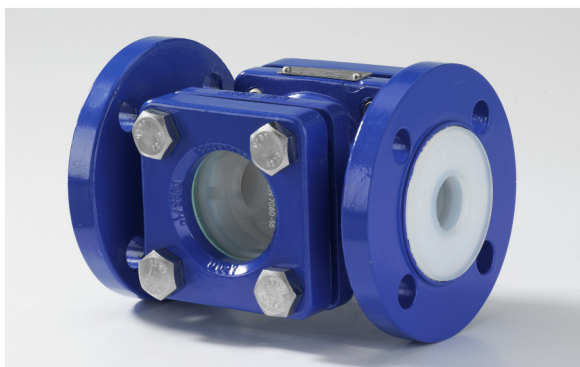

SSP
Body 1.0619 (WCB)/PFA

Main Features

- Heavy-duty, proven construction - maintenance-free
- Horizontal or vertical installation, flange connection acc. to DIN PN10/16 resp. ANSI 150lbs
- No need of additional flange gaskets due to wide and chambered flange sealing surface
- Standard drip ledge indicating even minute flows
- Large observation opening

 **Conformity according to European Pressure Equipment Directive 97/23/EC (PED)**

Options

- Metal reinforced glass plates
- Quartz glasses
- FEP glass protection sheet
- Visual flow indicator for gases (PTFE ribbon)

SSP Sight Glasses plastomer-lined

Operating Conditions

- Temperature range from -40°C (-40°F) up to $+200^{\circ}\text{C}$ ($+392^{\circ}\text{F}$), depending on lining material
- Pressure range from 1 mbar (0.01 psi) up to 16 bar (232 psi), depending on size/pressure/temperature

Testing / Marking

- Pressure- and tightness testing acc. to EN 12266-1, leakage rate A, resp. API 598.
- Marking of valves on body and name plate acc. to EN 19.
- Material- resp. test certificates acc. to EN 10204-3.1/2.2/2.1

Pressure-/Vacuum/Temperature Diagram

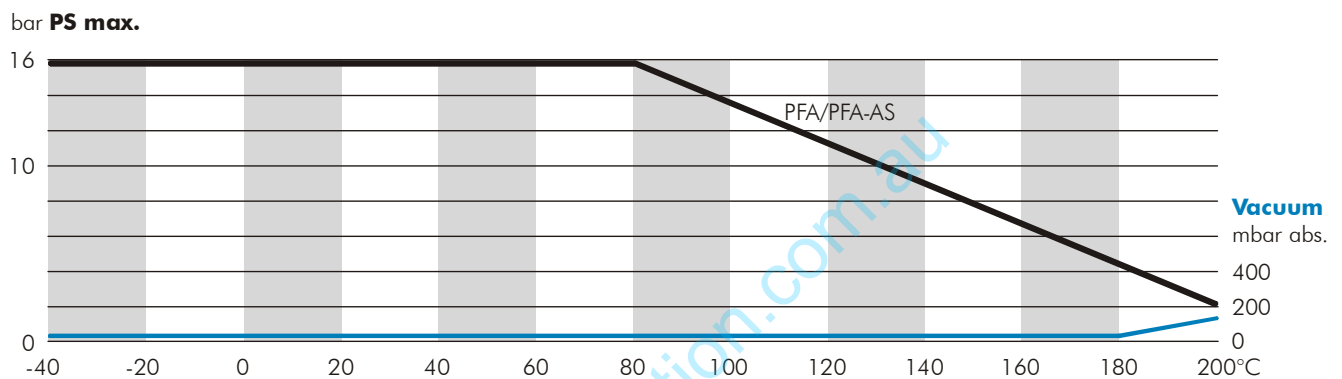

Technical Data

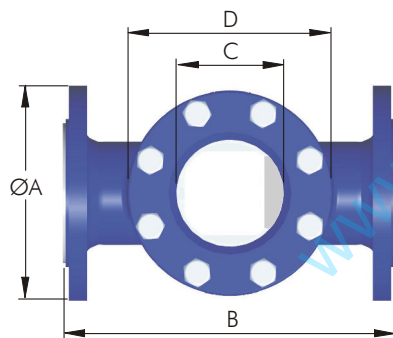

Standard Materials of Components

Body	Cast Steel 1.0619 (WCB) 5005 epoxy
Flange	Cast Steel 1.0619 (WCB) 5005 epoxy
Lining	PFA (opt. PFA-AS conductive)
Glass Plate	Borosilicate 8488 acc. to DIN 7080
Gasket	C-4400 asbestos-free
Bolts	A2-70 SS304

Dimensions in mm (lbs = kg x 2.2)

DN Size	15/1/2"	20/3/4"	25/1"	40/1/2"	50/2"	65/2/2"	80/3"	100/4"	150/6"
ØA DIN	95	105	115	150	165	185	200	220	285
ØA ANSI	95	105	108	127	152	178	190	229	279
B DIN	130	150	160	200	230	290	310	350	480
B ANSI	130	150	152	178	203	216	241	292	356
ØC	33	33	48	65	80	80	100	125	200
D	□70	□70	□85	□110	□120	Ø175	Ø190	Ø210	Ø290
ØGlass	45x10	45x10	63x10	80x12	100x15	100x15	125x20	150x25	225x30
kg DIN	3.6	4.2	5.2	8.8	13.0	19.3	26.8	46.5	61.8
kg ANSI	3.6	4.2	5.0	7.6	11.8	18.4	25.0	45.4	55.7

F/F acc. to DIN EN 558-1 Range 1 resp. ASME B16.10, other sizes and materials upon request
 Body flanges: 2 1/2" and 3" ANSI with threaded holes 5/8" UNC, 6" ANSI with threaded holes 3/4" UNC
 F/F options: 2 1/2", 3" and 6" available with DIN lengths

SSP Sight Glasses plastomer-lined

Parts List

Sight Glass compl.

Standard Version (Picture showing DN 80 PN16, PFA-lined)

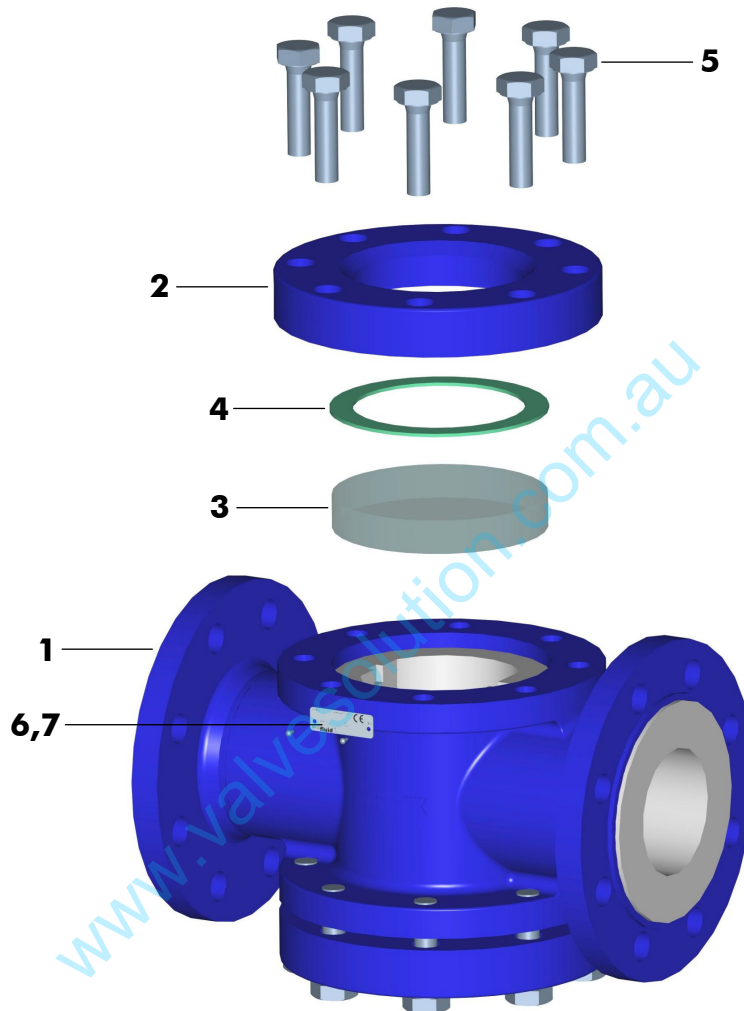

Item	Qty.	Description	Material	No.
1	1	Body PFA-lined, RAL 5005	WCB	1.0619
2	2	Flange, RAL 5005	WCB	1.0619
3	2	Glass Plate DIN 7080	Borosilicate	8488
4	2	Gasket	C-4400	
5	16	Hex. Head Screw	A2-70	1.4310
6	1	Name Plate 42 x 14 CE	A2	1.4301
7	2	Hammer Screw 2.49 x 4.76	A2	1.4310



SSP Sight Glasses plastomer-lined

Specification

Project-/Customer Data		Inquiry/Date: _____		Ref. SF	
Company:		Contact Person:		Phone:	
Address:		Function:		Fax:	
ZIP/Place:		Department:		E-mail:	
Project:		Phone direct:		Mobile:	

Operating Conditions

Media / Chemical Composition:

<input type="checkbox"/> liquid	<input type="checkbox"/> powdery	<input type="checkbox"/> crystallizing	<input type="checkbox"/> sticky	<input type="checkbox"/> Spec. Grav. ____
<input type="checkbox"/> gaseous	<input type="checkbox"/> Solids ____ %	<input type="checkbox"/> viscous	<input type="checkbox"/> Flow Velocity ____ m/s	
<input type="checkbox"/> abrasive	<input type="checkbox"/> Particle ____ mm	<input type="checkbox"/> Visc. ____ cp	<input type="checkbox"/> Flow Rate ____ m ³ /hr	

Pressure

max. ____ bar
min. ____ bar

Temperature

max. ____ °C
min. ____ °C

Mode

On/Off
 Flow Control
____ cycles/____

Installation / Environment

horizontal
 vertical
 Room dry
 Room humid
 outdoor

Remarks:

SSP Product Code

Specification of a complete Sight Glass SSP Series

Product code	Nom. size	Flange conn.	Body	Lining body	Glass plate	Options
SSP	DN50	PN16	G10	A85	Gb	
	DN15 - 150 ½" - 6"	PN16 PN40 ANSI150# ANSI300# JIS 10K	G10 WCB G15 CF-8M	A85 PFA A86 PFA-AS	Gb Glass plate PN16 Gb40 Glass plate PN40 Gr reinforced glass Gq Quartz glass	Op visual flow ind. RAL... special paint